

CITY OF LOS ANGELES
CALIFORNIA

BOARD OF
BUILDING AND SAFETY
COMMISSIONERS

VAN AMBATIELOS
PRESIDENT

E. FELICIA BRANNON
VICE PRESIDENT

JOSELYN GEAGA-ROSENTHAL
GEORGE HOVAGUIMIAN
JAVIER NUNEZ



ERIC GARCETTI
MAYOR

DEPARTMENT OF
BUILDING AND SAFETY
201 NORTH FIGUEROA STREET
LOS ANGELES, CA 90012

FRANK M. BUSH
GENERAL MANAGER

OSAMA YOUNAN, P.E.
EXECUTIVE OFFICER

Custom Cooler, Inc.
420 East Arrow Hwy
San Dimas, CA 91773

Attn: Steve Pearson
(909) 592-1111

RESEARCH REPORT: RR 25690
(CSI #13030)

Expires: December 1, 2018
Issued Date: November 1, 2016
Code: 2014 LABC

GENERAL APPROVAL – Renewal - Custom Cooler Incorporated Prefabricated Model 300 Refrigeration Panels for Walk-In Coolers and Freezers.

DETAILS

The panels consist of 3-1/2" to 5-1/2" thick high density foam or wooden frames with foamed-in-place rigid plastic core material manufactured by Dow Chemical Company and designated as: Voracor CE108, CE151, CE153, CE128, CE155, CE152, CE157 "A" side. Delta Therm AF4509 or Voracor CR1004 "B" side.

The skins are fabricated from 26 gauge galvanized steel with a minimum yield strength 33 ksi. The panels are held together by the use of cam-locking devices along the edges of the panels. Access holes for these devices are covered with metal or plastic plugs. Flame Spread and Smoke Development ratings per ASTM E84 are 20 and 300 respectively, for the foam (tested alone) and 15 and 250 respectively, for the foam with the skin described below. Density of the foam core is 2.2 + or -.2 pcf.

Custom Cooler Incorporated freestanding walk-in coolers and freezers constructed of panels described above are approved subject to the following conditions:

1. Use of the panels shall be limited to locations where combustible construction is permitted by the 2014 Los Angeles City Building Code.
2. The panels shall be fabricated in a shop of a licensed fabricator approved by the Los Angeles City Building & Safety Department. Fabrication in unlicensed shops will invalidate this approval.

RR 25690
Page 1 of 5

Custom Cooler Incorporated

Re: Custom Cooler Incorporated Prefabricated Model Refrigeration Panels for Walk-in Coolers and Freezers

3. A thermal barrier is required per Section 2603.4 of the 2014 Los Angeles City Building Code unless exempted per Section 2603.4.1.
4. Complete plans and calculations, signed and stamped by a civil or structural engineer or architect registered in the State of California, shall be submitted to the Structural Plan Check for their approval for each job.
5. An approved fire retardant roof covering (Class "A" or "B") shall be placed over the panels when used as exterior roof panels.
6. A separate approval from the Electrical Testing Laboratory shall be required for electrical installations within the panels.
7. Design of building utilizing the panels shall be in accordance with the requirements of the 2014 Los Angeles City Building Code and the design data specified

A. Panel Height Limitation (feet) and Maximum Concentric Axial Loads (PLF)

Thickness	Interior Panels	Exterior Panels (20 lb/sqft)	Maximum Axial Load (PLF)
4" wood Frame	30	18	600
4" foam Frame	24	13	300
5" wood Frame	31	20	600
5" foam Frame	28	14	300
6" wood Frame	32	21	600
6" foam Frame	30	15	300

B. Maximum Allowable Loads for Roof or Ceiling Panels
(W/F = Wood Frame) (F/F = Foam Frame)

Custom Cooler Incorporated

Re: Custom Cooler Incorporated Prefabricated Model Refrigeration Panels for Walk-in Coolers and Freezers

Span	t = 4 in. W/F	t = 4 in. F/F	t = 5 in. W/F	t=5 in. F/F	t = 6 in. W/F	t = 6 in. F/F
10'	53	49	65	65	79	79
12'	50	36	55	48	66	62
14'	37	27	47	37	57	48
16'	28	20	40	29	50	38
18'	22	16	32	23	42	30
20'	18	13	25	18	34	24
22'	14	10	20	15	27	20
24'	11	8	17	12	23	16
26'	9	7	14	10	19	13
28'	8	6	11	8	16	11
30'	6	-	10	7	13	10
32'	-	-	9	6	11	8

C. Maximum Allowable Shear Load of Wall Panels (PLF):

Shape Factor (Height:Width) Ratio	Allowable Shear (ppf)
0.5:1	400
1:1	200
1.5:1	133
2:1	100

D. Maximum Allowable Roof/Ceiling Diaphragm Shear

Shape Factor (Height: Width) Ratio	Allowable Shear (ppf)
0.5:1	400
1:1	200
1.5:1	133
2:1	100
3:1 MAXIMUM	67

The panels shall be continuous between exterior shear walls and shall not contain any openings or holes.

Custom Cooler Incorporated

Re: Custom Cooler Incorporated Prefabricated Model Refrigeration Panels for Walk-in Coolers and Freezers

E. Ceiling panel to wall panel connections are made with 3/8" dia. Lag screws or cam-locking devices, then a 26 gauge galvanized continuance angle cap is installed using #8 x 5/8" long tek screws (see attachment 1). The allowable shear and tension loads for the lag bolt connection are 573 and 472 pounds respectively. The allowable shear and tension loads for the camlock connection are 464 and 123 pounds respectively.

F. Maximum Allowable Loading for the Cam-Locking Devices:

	Wood Frame	Foam Frame
Tension parallel to panel face	386	168
Shear along longitudinal edge of panel in direction parallel to panel edge	280	147

8. Locations of connectors must be detailed on approved plans, the spacing of connections shall be calculated for each job but not less than two per width of panel (Width of panel = 46 1/2").
9. Allowable loads for shear walls and diaphragms are not applicable to buildings incorporating structural steel framing.
10. No increase in allowable stresses is allowed for the values indicated above for short duration of loads due to wind or seismic forces.
11. All design values and methods not included in this report shall be in accordance with requirements of the 2014 Angeles City Building Code.

DISCUSSION

The report is in compliance with the 2014 Los Angeles City Building Code.

The approval is based on tests on the foam per requirements of Sec. 2603 of the 2014 Los Angeles City Building Code, tests conducted in accordance with ASTM E-84 on the finished panels, and load tests conducted in accordance with ASTM E-72.

Addressee to whom this Research Report is issued is responsible for providing copies of it, complete with any attachments indicated, to architects, engineers and builders using items approved herein in design or construction which must be approved by Department of Building and Safety Engineers and Inspectors.

Custom Cooler Incorporated

Re: Custom Cooler Incorporated Prefabricated Model Refrigeration Panels for Walk-in Coolers
and Freezers

This general approval of an equivalent alternate to the Code is only valid where an engineer
and/or inspector of this Department has determined that all conditions of this Approval have
been met in the project in which it is to be used.



QUAN NGHIEM, Chief
Engineering Research Section
201 N. Figueroa St., Room 880
Los Angeles, CA 90012
Phone- 213-202-9816
Fax- 213-202-9943

QN
QN
RR25690/MSWord2013
R11-11-16
TLB1600348
2603

Attachment: Panel Connection Detail (2 Pages).

ATTACHMENT 2

WALL TO FLOOR CONNECTIONS

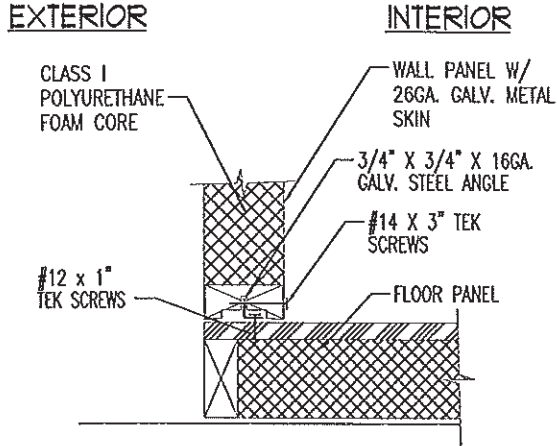

WALL TO PRE-FAB FLOOR

(A)

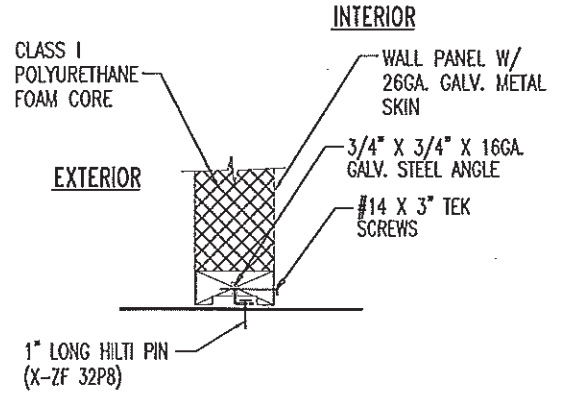

WALL TO CONCRETE FLOOR

(B)

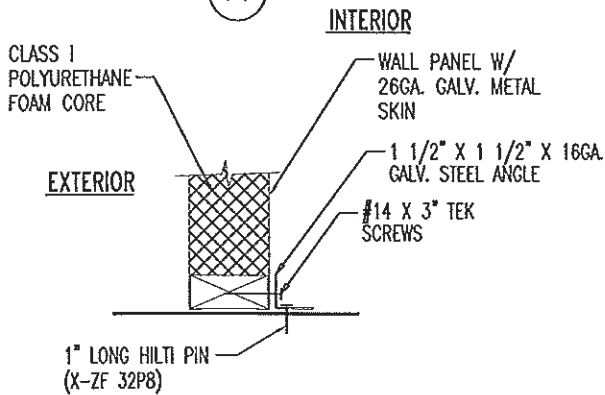

WALL TO CONCRETE FLOOR

(C)

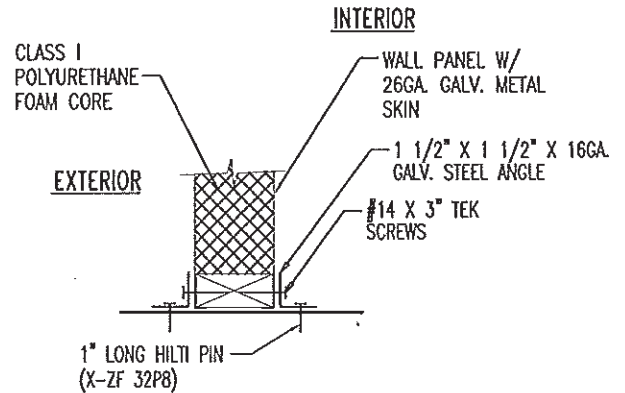

WALL TO CONCRETE FLOOR

(D)

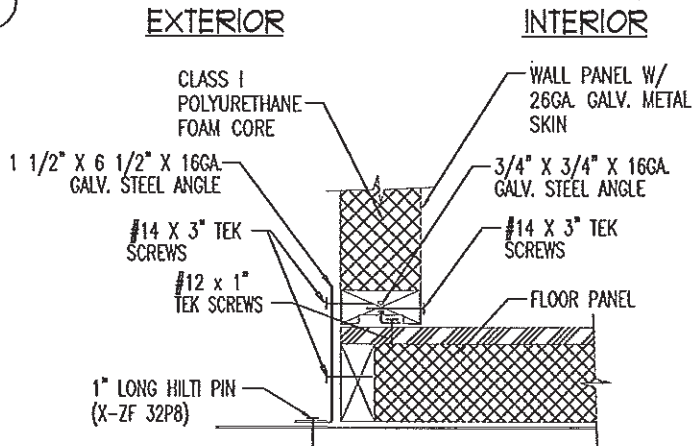

WALL TO PRE-FAB FLOOR

(E)

RR 25690

ATTACHMENT I PANEL CONNECTIONS

